



Centrifugal Sand Separators

For Centrifugal Removal of Sand, Silt and Gravel from Water



Industrial, Commercial & Municipal

Centrifugal Sand Separators

Time.
Quality.
Experience.
Knowledge.

Yardney Centrifugal Sand Separators

are ideal for removal of suspended solids and inorganic materials with a specific gravity of 2 or greater. This highly effective system will provide consistent, simple removal of inorganic material down to 75 microns. Easily installed, these carbon steel units are rated to 150 psi with threaded or flanged inlet/outlet connections. Smaller models are designed for vertical installation while larger models are angled and floor or ground mounted.

Sizing must be within the specified flow range for proper centrifugal action.

Larger flow separators and custom designed systems are available.



Applications

- Removal of sand, rock, grit and other inorganic contaminants with fine filtration down to 200 mesh or 75 microns
- Storm water runoff, industrial process water, incoming plant water, waste water clean-up, industrial water for plant reuse
- 150 psi standard operating pressure (high pressure systems available)
- Flow ranges from 4 gpm
- Removal of solids with a specific gravity of 2 or greater
- Serves as an excellent pre-filter to allow for improved sand media or screen filter performance by removing the gross solids from the water source

Advantages

- Sand removal efficiency of 98% of solids down to 200 mesh or 75 microns
- Multiple units in series provide higher efficiencies of filtration
- Units are available in ASME code or non-code construction
- Available with a manual or automatic solids purge valve system
- Special alloys and linings are available for prolonged life in required applications
- Made in USA

SPECIFICATIONS CENTRIFUGAL SAND SEPARATOR Vertical							
Model	Minimum Flow		Maximum Flow		Inlet/Outlet NPT Threaded	Purge Port	Particle Size Maximum
	gpm	m ³ /hr	gpm	m ³ /hr			
PCS-5V	4	1	10	2	1/2"	1"	3/8"
PCS-7V	10	2	20	5	3/4"	1"	3/8"
PCS-10V	18	4	38	9	1"	1"	1/2"
PCS-12V	26	6	52	12	1 1/4"	1"	1/2"
PCS-15V	38	9	79	18	1 1/2"	1"	1/2"
PCS-20V	63	14	120	27	2"	2"	1/2"
PCS-25V	100	23	180	41	2 1/2"	2"	1/2"
PCS-30V	125	28	260	59	3"	2"	1/2"
PCS-40V	190	43	345	78	4"	2"	1/2"

SPECIFICATIONS CENTRIFUGAL SAND SEPARATOR Angled							
Model	Minimum Flow		Maximum Flow		Inlet/Outlet ANSI 150# Raised Face Flange	Purge Port	Particle Size Maximum
	gpm	m ³ /hr	gpm	m ³ /hr			
PCS-40LA	200	45	400	91	4"	2"	1 1/2"
PCS-60LA	365	83	960	218	6"	2"	1 1/2"
PCS-80LA	800	182	1600	364	8"	2"	1 1/2"
PCS-100LA	1300	295	2300	523	10"	2"	1 1/2"
PCS-120LA	2025	460	3400	773	12"	2"	1 1/2"
PCS-140LA	2975	676	5000	1136	14"	2"	2"
PCS-160LA	4000	909	6200	1409	16"	2"	2"
PCS-180LA	5000	1136	7800	1773	18"	2"	2"

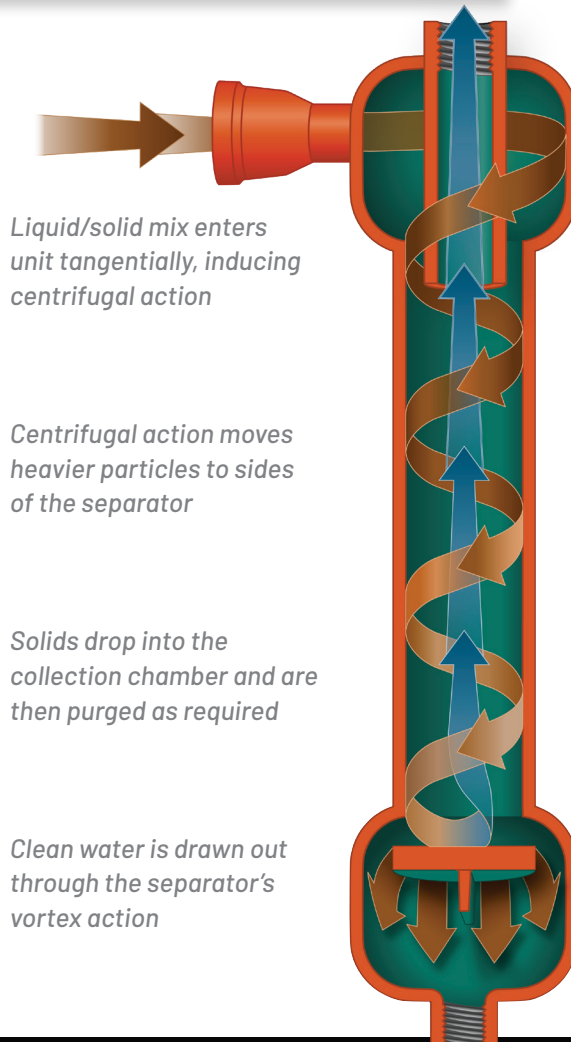

Standard assembly includes:

- Welded carbon steel
 - Vertical models include female threaded inlet and outlet connections and a threaded purge port for purging of contaminants or hookup of automatic flush valve
 - Angled models include flanged inlet and outlet connections and a threaded purge port for purging of contaminants or hookup of automatic flush valve

Available options:

- ASME code
- High pressure
- Special metal alloys and coatings for extended product life
- Ability to disassemble unit for inspection through flanged manways
- Automatic purge valve for flushing of filter
- Wall mount kit on smaller units

Centrifugal Sand Separators

Specifications

DIMENSIONS | Angled

Model	A	B	C	D	E	F	G	H	I	J	K
PCS-40LA	48 1/2"	46 1/2"	46 1/2"	16 11/16"	16"	7 1/2"	19"	4"	6 5/8"	12"	80"
PCS-60LA	63"	59 1/2"	60 3/8"	20 1/2"	20 3/4"	10 1/2"	22"	5 1/4"	10 3/4"	16"	106 1/4"
PCS-80LA	71"	65"	66"	21 3/4"	22 5/8"	12"	24 1/2"	5 5/8"	12 3/4"	18"	114"
PCS-100LA	78"	71"	72 3/4"	21"	24 1/2"	13"	29"	7"	16"	22"	123 1/2"
PCS-120LA	102"	75 1/4"	76 1/2"	23 3/4"	26 5/8"	14 1/4"	32"	8 1/8"	18"	26"	139"
PCS-140LA	102 1/2"	85 3/8"	86 5/8"	24 1/2"	27 3/4"	12"	33 1/2"	9"	20"	28"	152 1/2"
PCS-160LA	108"	89 1/4"	90"	24 3/8"	29"	12"	33 1/2"	9"	24"	30"	160"
PCS-180LA	118 1/2"	98 1/4"	100 1/4"	27"	33 5/8"	15"	34 1/2"	11"	28"	36"	177"

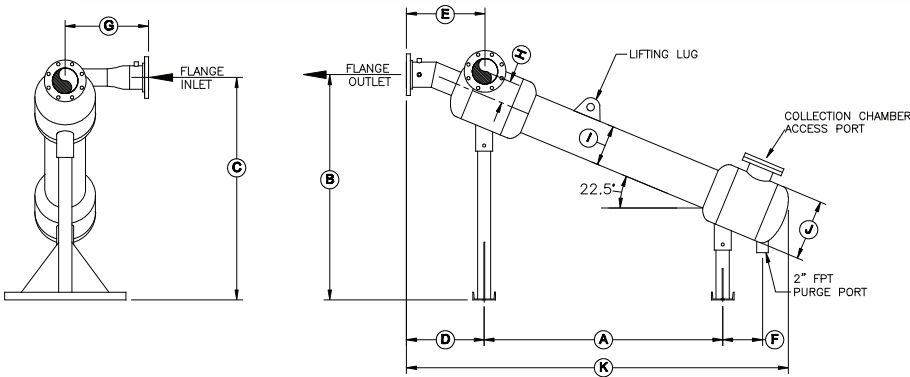

DIMENSIONS | Vertical

Model	A	B	C	D
PCS-5V	21 1/2"	6"	2 3/8"	2 1/2"
PCS-7V	21 1/2"	6"	2 3/8"	2 1/2"
PCS-10V	30 1/2"	6"	3 1/2"	2 3/4"
PCS-12V	30 1/2"	6"	3 1/2"	3"
PCS-15V	30 1/2"	6"	3 1/2"	3 1/8"
PCS-20V	38"	8"	4 1/2"	3 5/8"
PCS-25V	43 3/4"	10"	4 1/2"	4 1/2"
PCS-30V	47 1/2"	10"	5 9/16"	5"
PCS-40V	49"	12"	6 5/8"	6"

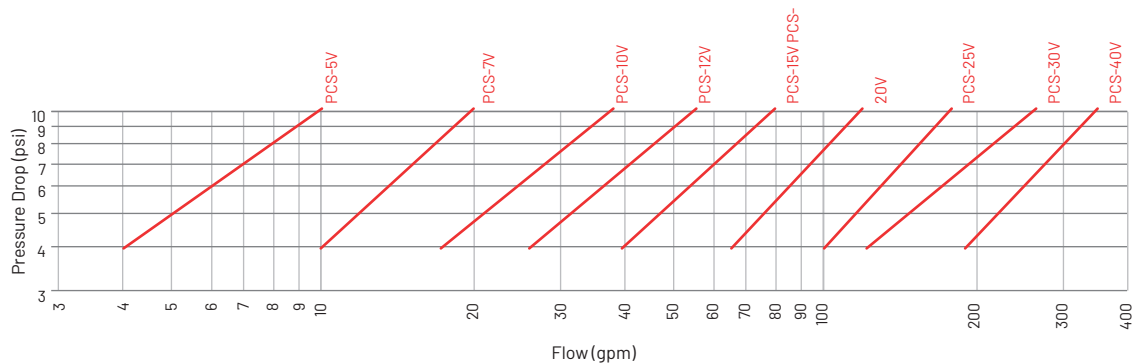
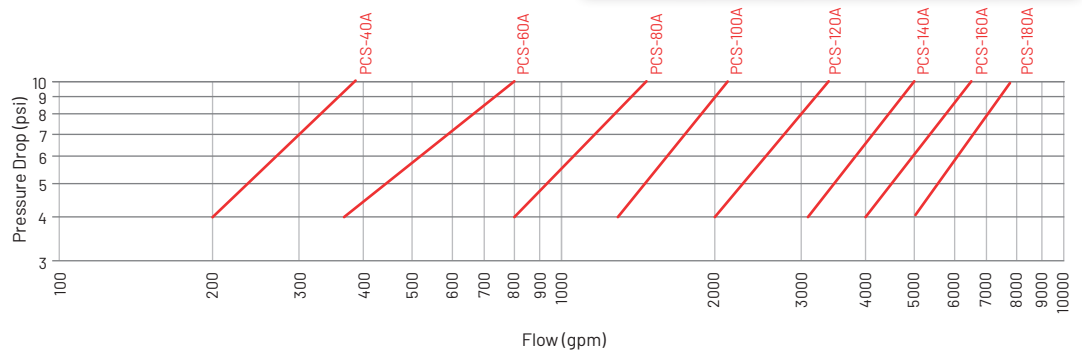
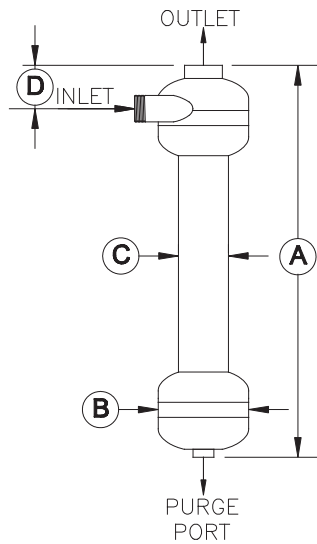

Made in USA

Phone: 951.656.6716
 Toll-Free: 800.854.4788
 Fax: 951.656.3867
 info@yardneyfilters.com



www.yardneyfilters.com